

**ANALYSIS AND REPRESENTATION OF REQUIREMENT TRACEABILITY****M. Z. Raza*, M.K. L. Bhatti, M. Tahir, W.Q. Awan, M. Siddique and Javaria**

* Department of Electrical Engineering, NFC Institute of Engineering and Technology Multan

DOI: 10.5281/zenodo.264063**KEYWORDS:** Concentrated Solar Power (CSP), Maximum Power Point Tracking (MPPT), Stirling Engine, LDR.**ABSTRACT**

The renewable energy system is the foremost alternative for power generation as the energy crisis is increasing and the fossil fuel reserves are depleting. Out of many renewable energy systems the solar thermal or solar PV system is the optimum solution. Our Purpose is to design the power system based upon Concentrated Solar Power (CSP) and PV for an efficient electric power production for the domestic purpose. Thus calling it Hybrid CSP system, we have designed the CSP system using the Stirling engine which is operated by the thermal input collected by a parabolic thermal concentrator. The mechanical output of the Stirling engine is synchronized with the electric generator to produce the electric power. Beside it the 2-D solar tracker is used to align the concentrator exacting with sun to get maximum thermal efficiency. The efficiency of the engine is improved by the parameters like heating and cooling temperature, fluid pressure inside the cylinder, volume swept by piston and type of fluid used. Beside CSP, a traditional PV system is hybrid with CSP to power a common load. The system is unique in this purpose that it requires no external power but its tracker is operated by PV section.

INTRODUCTION

The energy requirement is increasing as the population of world and industrialization is growing by leaps and bounds, ultimately causing the rapid depletion of fossil fuel reserves, which is feared that world will soon be run out of these resources. Fossil fuels are fundamental source of electrical energy. It is a matter of concern as the economy of world heavily leans on energy. Renewable energy source are the best alternative to cope with energy problem due to lack of fuels. Solar radiations are the optimum alternative for the energy production especially for country like Pakistan where the application of solar system seems to be inevitable due to abundant sunshine throughout the year especially in the sub-continental lowland regions like Multan.

An essential requirement of design of a solar energy system is the precise knowledge of the availability of global solar radiation for the site. Multan is

Table 1 Values of H for Multan [3]

Month	H_c Angstrom
Jan	11.21
Feb	13.85
Mar	16.64
Apr	20.42
May	21.66
Jun	21.81
Jul	20.59
Aug	18.45
Sep	15.15
Oct	12.35
Nov	10.41
Dec	0.663



Global Journal of Engineering Science and Research Management

located at 71°36'E Longitude and 30°15'N Latitude. The study is made to check viability of the region for Solar system design. We observed the region on bases of Angstrom–Prescott–Page Model which is most commonly used model for the estimation of monthly average daily global solar radiation (H) measured in MJm⁻²is of (Angstrom. et. al.)

$$H=H_0 * a+b (n/N) \quad (\text{Caleb C. Lloyd et. al.})$$

Where H₀is the monthly average daily extra terrestrial radiation, n is the day length, N is the maximum possible sunshine duration, a and b are empirical coefficients signifying the measurement of the overall atmospheric transmission under the total cloudy condition (n/N = 0) and the rate of increase of H/H₀ with n/N respectively.

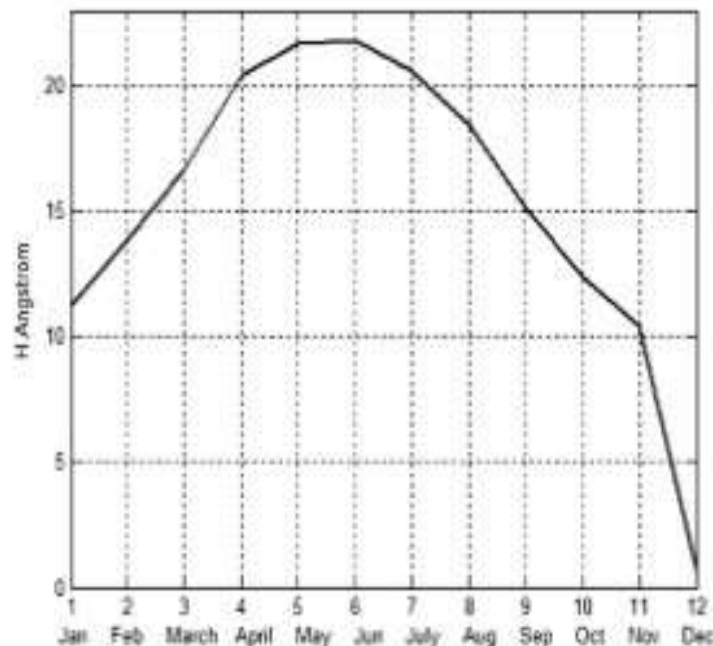

Fig 1: Daily global solar radiation of Multan

Average Value of H per year = 15.26691 MJ/m²

The solar constant (k) is 1.367kW/m². The calculations showing the viability of solar system design for the region.[1][7]

SOLAR ENERGY SYSTEM

As solar Energy Application are classified into photovoltaic (PV) and solar thermal. Traditional PV specially implies the PV panel attached with a charge controller device to charge battery bank. The traditional PV system's efficiency can be improved by the MPPT technique in the charge controller device or by using lenses and mirror to intensify more sunlight on the solar panels which is term as Concentrated Photovoltaic (CPV). Solar thermal is the technique to utilize the radiation of sun as heat to input the Stirling engine, the sunbeam is collected using parabolic concentrator, mirror, Fresnel lenses or radial concentrator in order to harvest the solar power.[7]

The hybrid system of PV and Stirling engine is developed to accommodate the domestic purposes in order to overcome energy crisis of the country. The system design is unique in the sense "no external Power" system which implies that the system (tracker) is operated by the PV portion, hence one can say this system comprise of Stirling engine and PV collimate with each other and entirely controlled by solar tracking system. PV system is defecating power into battery bank via MPPT based charge controller. (D.M. Whaley et. al)

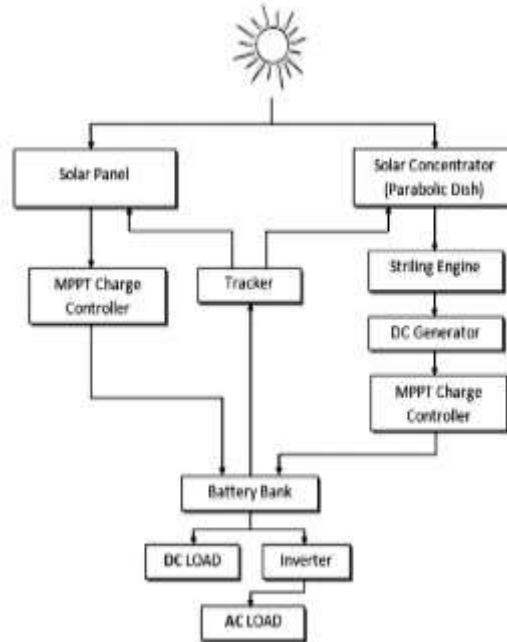

Fig 2.1 Block diagram of System

CSP STIRLING ENGINE SYSTEM

The Stirling engine was invented by Robert Stirling in 1816. The Stirling engine is one of the heat engines which are operated by cyclic compression and expansion of the working fluid, at the different temperature levels such that there is a net conversion of heat energy into mechanical energy. Fluid is enclosed in the cylinder.[2]

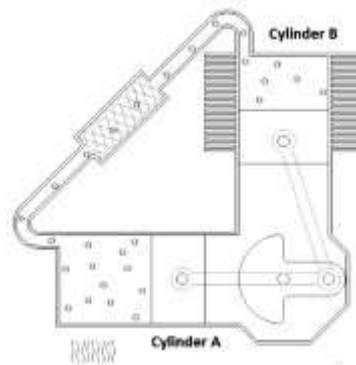

Fig 3.1 Stirling Cycle

Stirling engine is an external combustion engine and unlike internal combustion engine like gasoline or diesel engine no heat is produce inside the engine itself, which give advantage of its low maintenance and no gases and air to exhaust out, ultimately increasing its efficiency. The working fluid is mostly gases (air, hydrogen or helium) which tediously affect its efficiency and is further explained. The principle is that of thermal expansion and contraction of this fluid due to a differential temperature. (D.M. Whaley et. al.)[2]

Working Principle of Engine

The entire CSP system is divided into two parts:

- Heat energy to mechanical energy
- Mechanical energy to electrical energy



Global Journal of Engineering Science and Research Management

The first step is based on the principle describe below. The heat energy will be converted into mechanical output. The heat source can be anything but typically for our system it will be thermal heat of solar radiations. The ideal Stirling engine has four thermodynamic processes.

These processes can be explained into four steps:

Step1: Most of the gas in the system has just been driven into the hot cylinder. The gas heats and expands driving both pistons inward (refer fig 3.2). This step is called expansion.

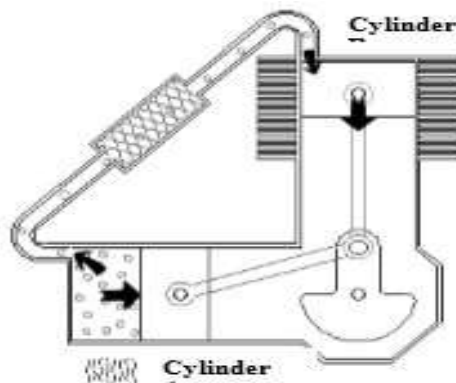

Fig 3.2 Gas at end of cylinder A expanding isothermally by absorbing heat from the source

Step 2: The gas has expand; most of the gas (about 2/3) is still located in the hot cylinder. Flywheel momentum carries the crankshaft the next 90 degree, transferring the bulk of the gas to the cool cylinder, where it get cool and the pressure drops (refer fig 3.3). This step is called transfer.

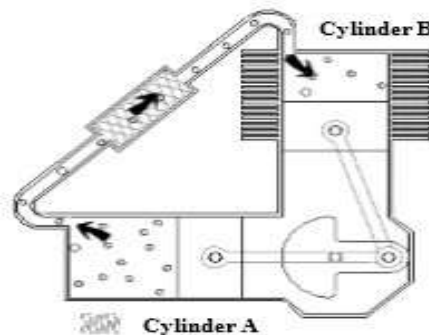

Fig 3.3 Gas transforming from A to B at constant volume

Step 3: The majority of the expanded gas has shifted to the cool cylinder. It cools and contracts, drawing both pistons outward (refer Fig 3.4). This step is called contraction.

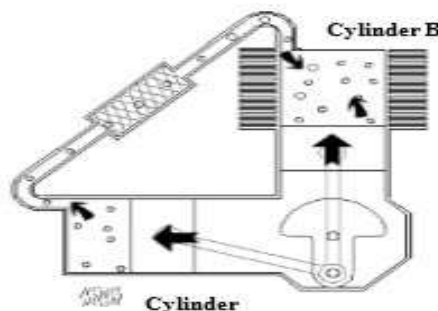

Fig 3.4 Isothermal compression of the gas from B to A



Step 4: The contracted gas is still located in the cool cylinder. Flywheel momentum carries the crank another 90 degrees, transferring the gas back to the hot cylinder to complete the cycle (refer Fig 3.5). This is called transfer.

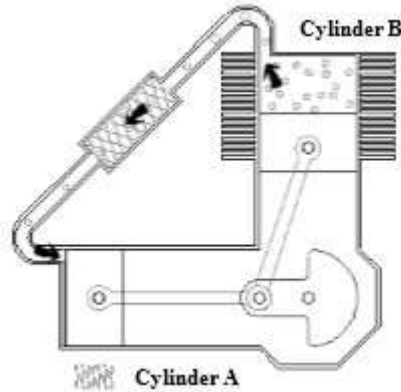

Fig 3.5 Gas expanding isochoric in A

Thus, this cycle repeats to produce rotary motion at the output, thereby converting heat energy into mechanical energy. (Caleb C. Lloyd et. al.) [3]

STUDY AREA

Gamma type Stirling engine is used to cope with our requirement due to its halcyon structure. The two cylinders are attached parallel to each other. As for the design is concerned, for any engine the biggest issue is the material used. Cast iron is used for cylinders while silver is used for pistons.

Now comes to the volume of cylinders, volume swept by the pistons, dead end volume and hot end volume for heat engine.

The Schmidt theory is used in the study to get the design parameters for the engine. [8]

Ideal gas equation:

$$PV = nRT \quad (1)$$

$$V_h = \left(\frac{V_d}{2} \right) * (1 - \cos(\phi + \psi)) + V_{deadhot} \quad (2)$$

Where;

- V_h is volume at high temperature
- V_d is the displacer volume
- $V_{deadhot}$ is the hot dead volume
- ψ is phase angle difference of displacer
- ϕ is angle of the crankshaft

$$V_b = \frac{(V_m)}{2} * (1 - \cos(\alpha)) + \frac{(V_d)}{2} * (1 + \cos(\alpha + \phi)) + V_m - V_{com} \quad (3)$$

Where;

- V_m is volume swept by power piston



V_b is volume at cold temperature

$V_{deadcold}$ the cold dead volume

Volume of portion of engine and mass of gas in those portions is:

$$V = V_h + V_b + V_r \quad (4)$$

$$m = m_h + m_b + m_r \quad (5)$$

V is total volume and m is total mass of gas. While h , b and r indicate volumes at hot temperature or cold temperature, and the one of the regenerator.

By applying ideal gas law, mass of gas in heat, cold and regenerator portion is derived.

$$m_h = P * \frac{V_h}{(R * T_h)} \quad (6)$$

$$m_b = P * \frac{V_b}{(R * T_b)} \quad (7)$$

$$m_r = P * \frac{V_r}{(R * (T_{mr} + dT))} \quad (8)$$

Where;

T is temperature

P is pressure

R is general gas constant

Total mass of gas:

$$m = P_o * \frac{V_{max}}{(R * T_o)} \quad (9)$$

P_o , V_{max} and T_o are the pressure, volume and temperature respectively at the moment of the filling the gas.

$$V_{max} = V_h + V_c + V_r \quad (10)$$

$$P = \frac{\left(P_o * \frac{V_{max}}{T_o} \right)}{\left(\frac{V_h}{T_h} + \frac{V_c}{T_c} + \frac{V_r}{(T_{mr} + dT)} \right)} \quad (11)$$

P is the pressure value inside the engine.

$$E_c = p * dV \quad (12)$$

Table 3.1 Concentrating Technologies

E_c is energy delivered by engine in one rotation.

$$P_t = energy * RPM \quad (13)$$

P_t is total power delivered by engine joule.

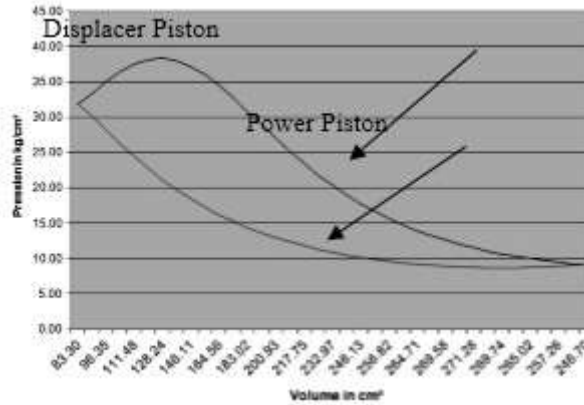

Fig 3.6 Pressure Volume Diagram

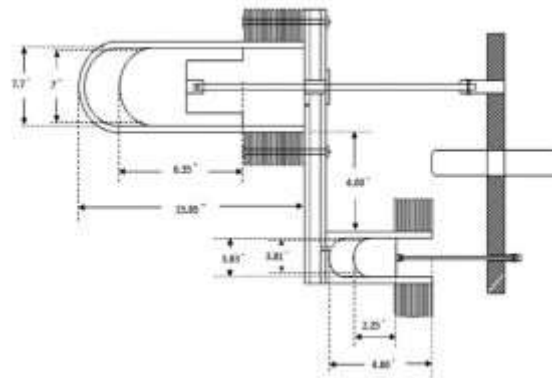

Fig 3.7 CAD diagram of calculated engine parameters

Solar Beam Concentrator

The table mentions concentrating technologies and their limitations:

	Optical method	Focus	Temperature (°C)
1	Parabolic mirror	Line moving	300-550
2	Linear Fresnel mirror	Line stationary	250-500
3	Linear Fresnel lens	Line moving	250-400
4	Solar tower with field of heliostats	Point stationary	300-1000
5	Solar dish	Point moving	400-1500
6	Fresnel lens	Point moving	400-1200



Global Journal of Engineering Science and Research Management

Solar beam concentrator is used for harvesting the solar heat energy so that it can be applied to the engine as input. The Stirling engine is based on differential temperature so heating side temperature is a big issue for the efficiency. The parabolic dish of 2m diameter is used in design to get about 5000C. The parabolic Collector is the aluminum and glass as reflector.

Improving Efficiency:

Now as the design has to do with efficiency the some step assisted our goal. The parabolic dish is used as concentrator that can give maximum 5000C at hot end of engine as the concern come with cold heat side as the engine's power is function of temperature difference. Well tradition cooling fins for air cooling is most in force but that cooling effect is improved by addition of cooling pipes within fins that would have increase the cooling effect by 30% practically ultimately increase the efficiency of the engine and cooling system is air as well as water cooling creating more differential temperature. The hot cylinder is painted black to gather more heat. [7] Another concern for the engine is gas used within the cylinder. Air, hydrogen and helium are most in effect. Hydrogen due to its high inflammability is not used. [4][7]

The efficiency of the engine according to gases used is given below:

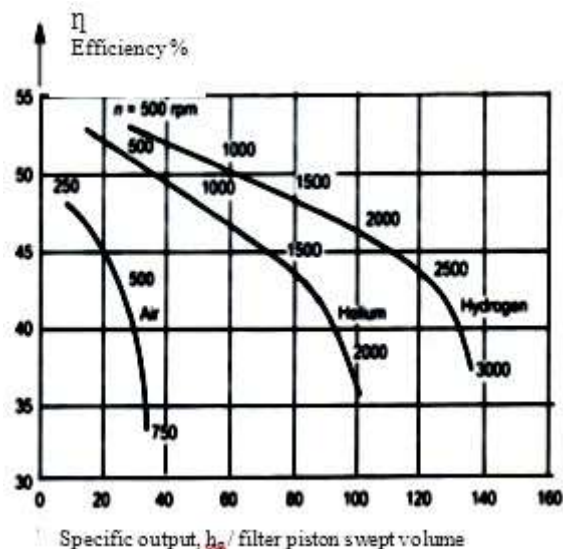

Fig 3.8 Efficiency at different gases

In order to perform practical we attach a Inflater Nozzle with the main cylinder in order to change gases and change pressure.

Table 3.1 Components of CSP system

Component	Details
Solar Beam Concentrator	Parabolic dish
Cooler	Cooling pins and water cooling pipes
Gas	Air/Helium
Inflator Nozzle	Yes
Piston material	Silver
Cylinder material	Cast iron



Average Pressure	2,306,827 Pascal
RPM	400-450
Power	500W(practically max)

METHODOLOGY

The mechanical output is now to be converted into electrical energy. Here use of generator is requisite for it. The Speed of engine is dependent on the differential temperature (amount of solar radiations) which will not be constant through-out the day, hence AC output will not be effective as its frequency can alter. DC output will be optimum way for charging battery bank. DC generators have very limited output of 100-200 Watt. A substitute to DC generators is "Alternators with Rectifier" to give DC output .Automotive alternators can be a good option, it differs from a dc generator in that it is without permanent magnets. Instead, there are two concentric wound coils of wire within the alternator: a stator coil (the outside coil which does not rotate) and a rotor coil (the inside coil, attached to the alternator's pulley, which does rotate). The rotor is also referred to as the alternator's "field." The voltage coming out of the alternator depends on two variables: the amount of current flowing through the field coil (i.e. the strength of the magnetic field) and the speed at which the alternator's field is rotating. does this by regulating the amount of current flowing to the field coil.

Once the alternator is self-sustaining, the only current flowing to the field originates from the alternator itself. If the output voltage is too high, the regulator lowers the current flowing to the field coil. If the output voltage is too low, the regulator increases the current flowing to the field coil. Simply put, as long as the alternator can maintain at least 14.4V across the battery, making the pulley spin faster or slower will have absolutely no effect on the power output. Power output in such a case will depend only on the load attached to the alternator. The initial current depends only on the resistance of the coil and the amount of charge of the battery connected to the field coil in case if engine is at low rpm. Tyally automotive alternators work at 2000-10000 rpm. The average rpm of engine is 450, hence by using gears ratio of 3:1 between crankshaft and the alternator we can give 1350 RPM to the alternator, using a certain amount of resistor to control field current we made the alternator optimum with the engine at this low speed. The issue is self-sustaining of the engine the field current is smart enough to get initial movement to engine to start its action, also starting alternator. The DC output is used to charger the battery bank. (N. Barsoum et. al.)[5]

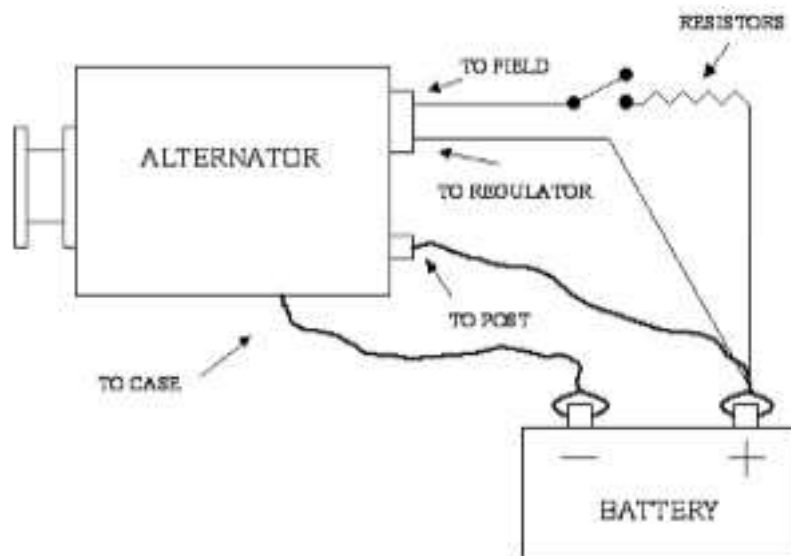

Fig 3.9 Connections of Alternator

The output power is calculated as $P_{DC}=3V_oI_o$, and V_{DC} is calculated as $1.283*\sqrt{3}*V_o$.

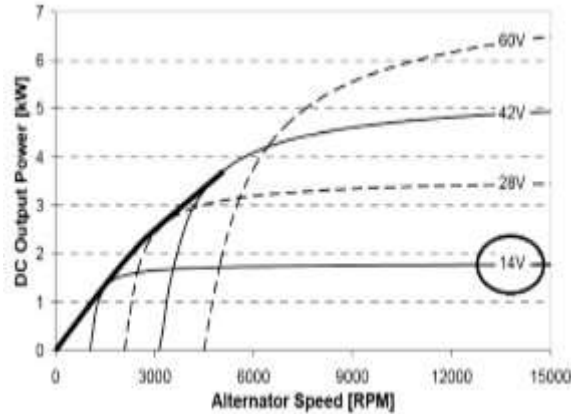

Fig 3.9 Alternator output power as a function of speed, at 14V, 28V, 42V and 60V (N. Barsoum et. al.)

Tracking System

A Power mechanism is used for the solar concentrator and it is driven by two motors for 2-D solar tracking. The tracking system allows the concentrator to track sun extracting during full day and all season of year especially winters. Solar tracker not only increases the efficiency of the system but it play a crucial rule for basic input of system. In our design, an automatic solar tracking system has been designed using LDR and DC motors on a mechanical structure with gear structure to control azimuth angle and elevation angle (2 Degree of freedom) of concentrator controlled by controller based logic. Tracking system used is closed-loop. The closed-loop tracking, the sun tracker normally sense the direct solar radiation falling on a photo-sensor as a feedback signal to ensure that the solar collector is tracking the sun all the time and keep the solar collector at a right angle to the sun's rays for getting the maximum solar insulation(S. Bockamp et. al.). Tracking system has been designed using four LDRs (Light Dependent Resistors) and two DC motors, each of pair of 2 LDR form a differential detector for each dimension. The each LDR is attached to the built-in ADC of controller.

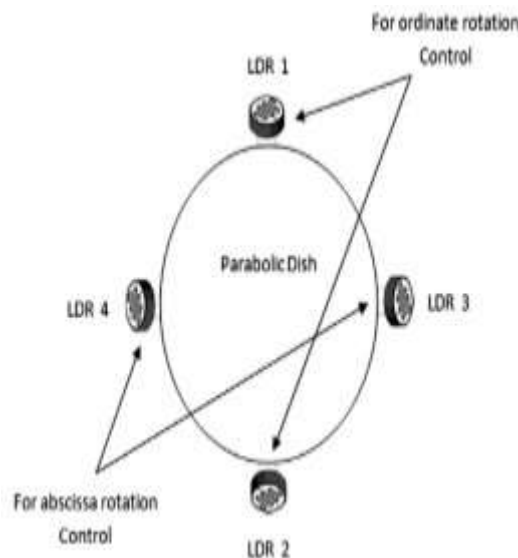

Fig 3.9 Solar Tracking System

The simple logic is implemented in the controller to drive motors according to the movement of sun. The motors are attached to the H-Bridge. The system is intelligent enough to detect the absence of sun and get the system back to its initial position. DC motors are geared in order to manoeuvre the concentrator.[6]



RESULTS

1) High efficiency:

It is function of the temperatures of the hot and cold sources. As it is possible to make it work in cogeneration so its efficiency is quite high.

2) Sources:

Beside Solar heat, this system can also be implemented into combustion of gases, wood, fuel of various industries and can be used in combine cycle.

3) Non-Polluting:

Unlike conventional energy system this system is with zero pollution.

4) Reliability and easy maintenance:

The technological simplicity makes it possible to have engines with a very great reliability and requiring little maintenance. It can be operated by even untrained persons.

Output Observational Analysis

The observational study for the output of the system was performed for one month, shown in the graph

below:

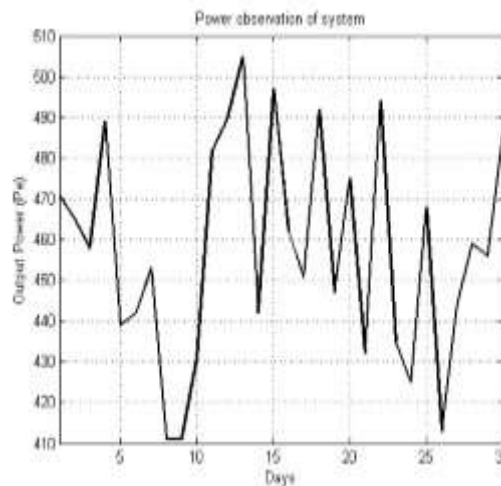

Fig 3.10 Output observation of CSP system

$$\text{Input Power} = P_{in} = k * \pi * \frac{D^2}{2} \quad (14)$$

$$\text{Output Power} = P_{out} = 0.015 * V * f * \rho \quad (15)$$

$$\text{Efficiency} = P_{in} - \frac{P_{out}}{P_{in}} * 100 \quad (16)$$

D is diameter of dish, k is solar constant, p is pressure in bar, f is Speed of Stirling engine in Hz (rpm/60), V is displaced volume of piston in cm³.

PV System: The secondary part of the study was traditional PV system. We observed a panel of 120W into our study, basic purpose of the study was to do a comparison with the CSP system. MPPT based charge controller was designed for the System using controller and Perturb & Observe algorithm.

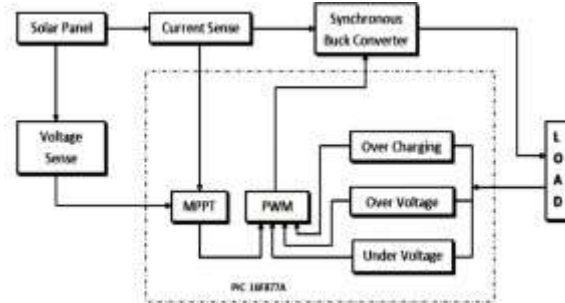

Fig 4.1 Block Diagram of designed MPPT Charge Controller 24V and 200AH acid Lead battery was used for the storage of the energy.

CONCLUSION

Hybrid CSP system is the direction of future power generation and foremost the reduction of the energy crisis in present situation specially for region having relatively greater daily solar radiations .The CSP system will be quite efficient to over-come continues power demand through-out the day and until the PV system CSP system can remain functional even in night by using suitable heat source like by molten salts, hence giving this system a completely renewable energy system. This system has ability to change to change the entire power production infrastructure and it must, because traditional ways will not stand much long, and biggest must no more “power shutdown” hats off to Robert Stirling for the Stirling engine and thanks to nature for providing us with renewable energy sources. More you harvest the solar power, less will be energy crisis.

REFERENCES

1. Angström “Solar and terrestrial radiation” Quart. J. Roy. Met. Soc. 50 (1924)
2. Caleb C. Lloyd “low temperature differential Stirling engine for power generation” By Caleb C. Lloyd
3. D.M. Whaley, W.L. Soong and N. Ertugrul “Extracting More Power From The Lundell Car Alternator” Australasian Universities Power Engineering Conference (AUPEC 2004)26-29 September 2004, Brisbane, Australia
4. Intikhab Ulfat, Firoz Ahmed, Farrukh Javed, Asif Usman and Faiza Kanwal “Recital of Some Existing Sunshine-Based Models of Global Solar Radiation for Selected Stations of Punjab, Pakistan: A Comparative Study” Karachi University Journal of Science, 2008, 36, 19-22.
5. N. Barsoum, “Implementation of a prototype for a traditional solar tracking system,” Third UKSim European Symposium on Computer Modeling and Simulation, pp. 23-30, 2009.
6. S. Bockamp, T. Griestop, M. Fruth, M. Ewert, H. Lerchenmueller, M. Mertins, G. Morin, A. Haberle, J. Dersch, "Solar Thermal Power Generation", presented at Power-Gen Europe 2003, Dusseldorf, Germany
7. Ulgen K. and Hepbasli A., Solar radiation models Part 2: “Comparison and developing new models, Energy Source 26” (2004).